



News Letter 4

UV: Atlas Chooses Kipp & Zonen
New Data Logger: LOGBOX SD
MTP5 Looks At The Italian Sky

Content

April 2008

P2: Ben's Column

P3: News update

Passion for Precision
AMS Annual Meeting
Product Updates

P4: Atlas Weathering Services

chooses Kipp & Zonen UVS Radiometers

P5: Introducing a new data logger:

LOGBOX SD

P6: Meteorological Temperature Profiler

looks at the Italian sky

P7: Insights

Establishing the Asia Pacific office
Meteo 2000 Weather Station by Mierij Meteo
Fairs & Events

Contact

If you have a news item for the news letter or want to share your experiences with Kipp & Zonen applications and contribute to our next issues, please e-mail the editor: kelly.dalu@kippzonen.com

© All rights reserved. No part of this publication may be reproduced, stored in a retrieval system or transmitted in any form or by any means, without permission in written form from the company.

Kipp & Zonen, 2008



Ben Dieterink

A Fresh New Look

A new edition for springtime, with a fresh new look. This is only the beginning of a complete corporate restyling that will take place throughout 2008.

Over the years the Kipp & Zonen logo has changed several times, reflecting changes in the company. The last change was the addition "Since 1830" in 2005 when we celebrated our 175 years anniversary. The main body of the logo however is more than 10 years old. We feel that it is now time for an update of our house style and to emphasize our key values.

Throughout the history of Kipp & Zonen the gas generator (the invention of Mr. P.J. Kipp) has always been part of the logo. I personally feel that we cannot abandon our heritage and should keep the gas generator in the heart of Kipp & Zonen.

The new house style expresses that we are not just an authority in solar radiation but also that we are a company with people that have passion for science, technology and quality, "Passion for Precision".

2008 is going to be an exciting year; a completely new house style, new product introductions and an agenda full of conferences, such as AGU, EGU, AMS and EMS (this year in Amsterdam). This year also sees the quadrennial International Radiation Symposium. IRS2008, will be held in Brazil, Foz do Iguaçu. The last edition of IRS was in Busan, Korea and very successful. We hope to welcome many of our customers at this symposium.

I trust that you will find our spring edition both entertaining and informative and that it gives you an insight to our company with development updates and practical stories from Italy, the USA and Singapore ■

Yours sincerely,

Ben Dieterink, President
Kipp & Zonen BV



Passion for Precision

Yes, something is different. Kipp & Zonen has been redesigned and we are very happy to share this new look with you.

The design bureau Bataafsche Teeken Maatschappij has done a great job translating our company values to a strong and fresh new logo. This new company logo reflects the progressive and forward-looking initiatives being implemented across our company. And what makes this redesign special is that it reflects the company we have become, while respecting our past. It represents durability, authority, passion, accuracy and authenticity.

The new logo is only the first step and this newsletter is one of the first results. Now we are working on a completely new website, scheduled to be launched this summer. The new website is being designed for easy accessibility of information and downloads.

We hope to see you at www.kippzonen.com soon!

AMS Annual Meeting

From 20th to 24th of January the American Meteorological Society (AMS) gathered at the 88th AMS Annual Meeting in New Orleans. For the eighteenth time in a row since 1990 Kipp & Zonen participated in the exhibition that is held in connection with the conference. In spite of the fact that the number of visitors as well as exhibitors dropped compared to last year, Kipp & Zonen still looks back to a successful exhibition.

On top of the regular attention which we get from our wide range of solar radiation instruments we experienced this year an increased interest in our atmospheric science instruments. Such as the MTP 5-Temperature Profilers and our LIDAR range. However, the highlight of the Kipp & Zonen stand was the new SOLYS 2 Sun Tracker.



During the five exhibition days Kipp & Zonen was delighted to speak with visitors from all different parts of the world ■

Product Update

CHP 1 Pyrheliometer

CHP 1 is our new first class pyrheliometer for high accuracy direct solar radiation measurement. CHP 1 will be available within this quarter. For information on instrument performance, specifications and features go to www.kippzonen.com.

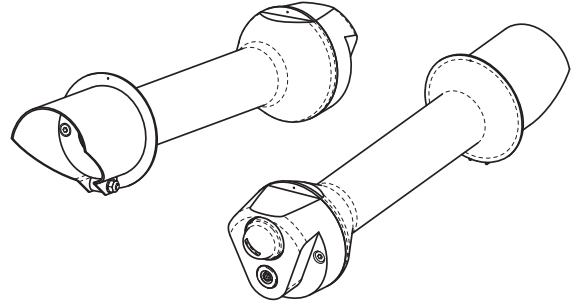

SOLYS 2 Sun Tracker

There has been considerable interest in the SOLYS 2 and the first production units available for customer delivery have all been sold!

An internal heater is now fitted as standard, allowing operation from - 40°C to + 50°C on AC power (- 20°C to + 50°C on 24 VDC power). Two multi-function LED's show the power, temperature and tracking status.



The full specifications can be found on our website and downloaded ■

Atlas Weathering Services chooses Kipp & Zonen UVS Radiometers

Kipp & Zonen is proud to announce the recent purchase of twenty-seven UVS broadband global UV-A and UV-A/B radiometers by Atlas Weathering Services Group of the USA. Atlas is a global leader in the field of material testing and advanced weathering services, with test laboratories located in New River, Arizona (DSET Laboratory) and South Florida (SFTS Miami and SFTS Everglades).

These weathering test sites utilize the latest technology in weather reporting instrumentation, such as total solar (Ultraviolet, Visible and Infrared), total UV and narrow-band UV radiometers, and pyr heliometers. The Atlas laboratory test instruments are directly traceable to national and international standards, including the World Radiometric Reference (WRR) and the National Institute of Standards and Technology (NIST).



Broadband UVS Radiometer

In the spring of 2005 Atlas made the decision to replace its ageing fleet of Total UV Radiometers and to host an independent inter-comparison amongst the leading broadband UV radiometer manufacturers to identify the best performing instruments available. Kipp & Zonen accepted the challenge with confidence and supplied a dual-band UVS-AB-T model to Atlas/DSET New River, Arizona for the inter-comparison. In addition to instrument performance, price, delivery time, and in-country support were all criteria of consideration. After a three month evaluation Atlas deemed Kipp & Zonen the victor.

As a result, Atlas purchased nineteen Kipp & Zonen UVS A-T and eight UVS-AB-T models for the Arizona and South Florida Test Facilities locations. These radiometers will be

used to acquire high accuracy global UV-A and UV-B solar irradiance data, in order to assess the short and long-term durability of manufactured goods to UV radiation.

Atlas offers a range of materials testing services, including outdoors accelerated weathering testing for characterizing short and long-term UV and visible solar radiation impact on manufactured goods. The range of materials tested includes plastics, rubber products, paints, textiles, and building materials. The test data supplied by Atlas to the manufacturer is critical for determining the durability of the end product; in many cases such material testing is compulsory to ensure that the manufacturer's products meet industry standards.



Intercomparison at Atlas' test facility in Arizona

Atlas also designs and builds turn-key weathering systems that are distributed world-wide, and is buying further Kipp & Zonen UVS radiometers to integrate into these systems ■

SUMMARY UVS RADIOMETERS

Atlas Weathering Services Group in the USA hosted an inter-comparison of broadband UV radiometers to identify the best model available to update their weathering test facilities in Arizona and South Florida. Kipp & Zonen's UVS series was the winner and 27 instruments are now deployed at the two sites ■

Kipp & Zonen introduces a completely new data logger: LOGBOX SD

Collecting meteorological parameters is a joint effort of a measuring instrument, such as a pyranometer, and a data logger. The sensitive outputs of our instruments need accurate data logging. The new and improved LOGBOX SD is the perfect logger for all meteorological applications.

LOGBOX SD is a 4 to 8 channel data logger that allows connection of multiple instruments at the same time. The data is stored on a low cost SD memory card. The 24 bits high resolution differential analog inputs can be easily configured for all our instruments, including Pt-100 and 10K thermistor temperature sensors. Each input can convert measured values to engineering units.

Four digital inputs are available for measuring time or frequency, or as counter inputs. LOGBOX SD has an IP 65 weatherproof enclosure and wide operating temperature range from -40°C to +60°C. The state of the art design consumes so little power that it will run for months on the internal batteries. The wide power supply operating range makes it also possible to use solar panels or other external power sources. The low power consumption, large storage capacity, wide temperature range and weatherproof box allow for months of unattended operation in remote locations. These features make LOGBOX SD the perfect logger for field use, or even for a complete weather station.

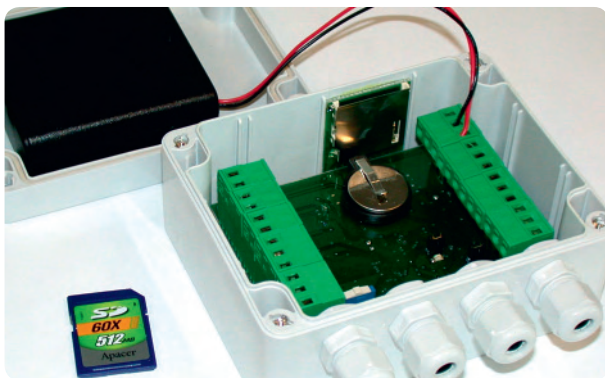

Inside the LOGBOX SD

LOGBOX SD is supplied with user-friendly software to make configuration fast and simple. All Kipp & Zonen radiometer settings are pre-defined and can be selected from a pull-down list. Any other sensor can be programmed by selecting an input range and defining the calculation to convert to the correct engineering units. The logging and storage intervals can be set separately and the total storage time will be shown.

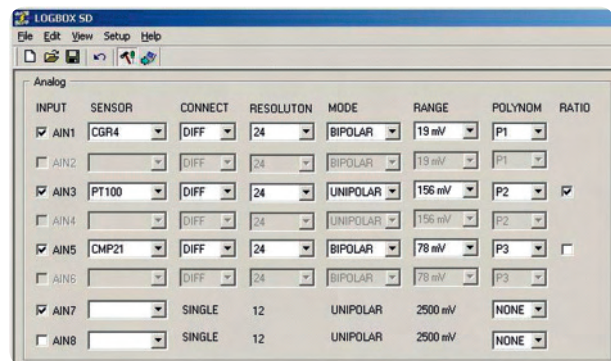

Sensor set-up screen

An internal memory of 128 kB is present and, like the 512 MB SD card, this memory is non-volatile. Even without batteries the data will remain stored.

LOGBOX SD is a completely new design and will replace the current LOGBOX during the second quarter of 2008.

For more specifications go to www.kippzonen.com ■

SPECIFICATIONS

Analog Inputs	8 unipolar or 3 differential + 2 unipolar, or combinations
ranges	8 ranges from 2.5V down to 20mV
voltage resolution	1µV
Accuracy	0.05% (for 24 bits resolution)
Digital Inputs	4, with maximum input 15 Volt
Power Requirements	supplied with 4 x AA type batteries
external supply	4VDC to 20VDC
power consumption	1,7mA typical during measurement
Real-Time Clock Accuracy	50ppm
Memory	128kB for data
memory card	SD card (512 MB included)
Communication	RS232 or RS485
Temperature Range	-40°C to +60°C

PASSION FOR PRECISION

MTP 5 Meteorological Temperature Profiler looks at the Italian sky

The MTP 5 has become a major success story in Italy. Thanks to the efforts and expertise of our distributor Eurrelletronica Icas S.r.l. Italy has the highest number of MTP 5's outside Russia.

MTP 5 is a passive microwave radiometer designed to measure accurately in real time the atmospheric temperature profile from the ground to an altitude of 600m (-H) or 1000m (-HE). The technique is based on the measurement of thermal radiation from the atmosphere at the centre of the molecular oxygen absorption band. MTP5 operates automatically in a large range of meteorological conditions, without any radiation emission, is self-calibrating and has low maintenance and operating costs.

The first application in Italy was in early 2000. The National Research Centre (CNR) purchased a MTP 5-P for scientific research in Polar Regions. Since then it has been used in measurement campaigns in Antarctica at the Concordia Base on Dome C.

MTP5 is a useful tool to provide the Planetary Boundary Layer (PBL) temperature profile and to monitor the development and break-up of temperature inversions. These are an important factor in the accumulation of PM10 particulates, a critical pollutant, especially in the winter. MTP 5 data are key inputs to models that predict the dispersion of accidental gas releases. Within this context, Regional Agencies for the Protection and Prevention of the Environment (ARPAs) have become interested in the features of MTP 5.

In 2003 the first MTP 5 for monitoring in an urban area in Italy was procured by the ARPA of the Piemonte Region. This was installed in the city of Torino, in combination with a Vaisala Wind Profiler.



Installation at ARPA Piemonte, City of Torino

In 2004, in response to frequent air quality emergencies in the north-eastern region, especially during the cold season, ARPA Veneto procured three MTP 5 radiometers to monitor low-level atmospheric stability and temperature inversions. The three units are installed in urban and rural areas (Padova, Rovigo and Belluno).



Installation at ARPA Veneto, City of Padova

In 2007, in the Piemonte Region, two MTP 5 instruments were installed at power plants; one at the Iride Energia plant in Torino Moncalieri and the other at the new ACEA Electrabel plant in Leinì. The purpose of these instruments is to monitor how the thermal behaviour of the atmosphere influences emissions from the plants.



Team picture: front row, from left: M. Mariano, A. M. Leccese, B. Vagnozzi, M. R. Leccese, back row, from left: G. Pomponi, R. Icardi, V. Borgognoni, S. Bonfini

A new MTP 5 was recently procured for installation at Rome Fiumicino airport, for studies of thermal inversions in connection with fog forecasting. The installation will be completed during summer 2008 ■

SUMMARY MPT 5

Eurelletronica Icas S.r.l. is the dedicated distributor of Kipp & Zonen products in Italy. They have become specialists in the MTP 5, with customers who have deployed instruments in urban, rural and industrial locations. From a Polar MTP 5 for climate research in the Antarctic, to a network of three instruments in the Veneto region to monitor Planetary Boundary Layer phenomena. There are MTP 5's at power stations in the Piemonte Region and the latest installation is at Rome's Fiumicino airport to study the development of fog ■

Establishing the Asia Pacific office

Now, a year later, we can look back at a great journey and ahead to an exciting future. A lot of interest in both solar radiation instruments and our atmospheric science range generated good results for a first year.

The increasing awareness of environmental issues and rising oil prices are hot topics. This is leading to research on alternative sources of energy and an increasing cooperation between the APAC countries to protect the environment from the effects of industrialization.



Mr. Benjamin Pereira

In the past year Kipp & Zonen APAC established reliable sales channels to respected governmental agencies and research universities. Sales include a Polar version of the MTP 5 (Meteorological Temperature Profiler) to Australia and a complete solar radiation network in Thailand. Our pyranometers and net radiometers have been integrated into the Automatic Weather Stations of several leading AWS suppliers in the region.

Kipp & Zonen Asia Pacific is now well established and looking forward to enhancing our market share and position in APAC, together with our trusted agents and distributors ■

Meteo 2000 Weather Station

Mierij Meteo designs and builds high quality systems for measuring meteorological phenomena and is specialised in wind. The Meteo 2000 is one of their best-selling weather stations. It consists of wind sensors, an outdoor temperature sensor and an indoor display panel.

The set of wind sensors includes an anemometer and a wind vane, mounted on a single bracket. These sensors measure wind speed and wind direction using an optical system that has no moving electrical components and therefore provides a long operating life. The temperature sensor is fitted in a white radiation shield, that protects the temperature sensor from the influence of direct solar radiation and precipitation.



Meteo 2000 weather station

The radiation shield protects the temperature sensor from the influence of direct solar radiation and precipitation.

Please visit www.mierijmeteo.nl for more information about Meteo 2000 and their extensive range of professional-grade Meteo Stations ■

Fairs & Events

European Geosciences Union - Austria	13-18 April '08
Green Energy Expo, Daegu City - Korea	21-23 May '08
ILRC - International Laser Radar Conference, Boulder, Colorado - USA	23-27 June '08
Quadrennial Ozone Symposium - Norway	29 June '08

PASSION FOR PRECISION

Kipp & Zonen is the worldwide authority in measuring solar radiation and atmospheric properties. Our passion for precision has led to the development of a large range of high quality instruments: from all weather resistant Pyranometers to complete measurement networks.

We promise our customers guaranteed performance and quality in various markets: Meteorology, Climatology, Hydrology, Industry, Renewable Energy, Agriculture and Public Health & Safety.

We hope you will join our passion for precision.

HEAD OFFICE

Kipp & Zonen B.V.

Delftechpark 36, 2628 XH Delft
P.O. Box 507, 2600 AM Delft
The Netherlands

T: +31 (0) 15 2755 210

F: +31 (0) 15 2620 351

info@kippzonen.com

SALES OFFICE

Kipp & Zonen France S.A.R.L.

7 Avenue Clément Ader
ZA Ponroy - Bâtiment M
94420 Le Plessis Tréville
France

T: +33 (0) 1 49 62 41 04

F: +33 (0) 1 49 62 41 02

kipp.france@kippzonen.com

Kipp & Zonen Asia Pacific Pte. Ltd.

583 Orchard Road
16-01 Forum Building
Singapore 238884

T: +65 (0) 6735 5033

F: +65 (0) 6735 8019

kipp.singapore@kippzonen.com

Kipp & Zonen U.K. Ltd.

P.O. Box 819,
Lincoln, Lincolnshire
LN6 OWY
United Kingdom

T: +44 (0) 1522 695 403

F: +44 (0) 1522 696 598

kipp.uk@kippzonen.com

Kipp & Zonen USA Inc.

125 Wilbur Place
Bohemia
NY 11716
United States of America

T: +1 (0) 631 589 2065

F: +1 (0) 631 589 2068

kipp.usa@kippzonen.com

Go to www.kippzonen.com for your local distributor or contact your local sales office

